

## Screw Conveyors & Screw Feeders

### New Design & Replacement Components

Screw Conveyors are used to efficiently convey bulk materials from one process to another. Screw conveyors are very cost-effective and require minimal maintenance to operate. They are ideal for conveying dry to semi-fluid materials – free-flowing to sluggish and efficiently distribute bulk materials to various locations using multiple discharge points. They can be totally enclosed for corrosive or hazardous environments.

Replacement Parts Include:

- ✓ Conveyor Screw
- ✓ Couplings & Bolts
- ✓ Hangers & Bearings
- ✓ Trough Ends
- ✓ Troughs, Covers, Clamps & Shrouds
- ✓ Trough Liners & Discharge Spouts
- ✓ Drive components
- ✓ Support Feet & Components
- ✓ Carbon, AR, Stainless & Galvanized Steel

Davis Industrial has highly trained technicians available to help with your screw conveyor and mechanical maintenance needs.

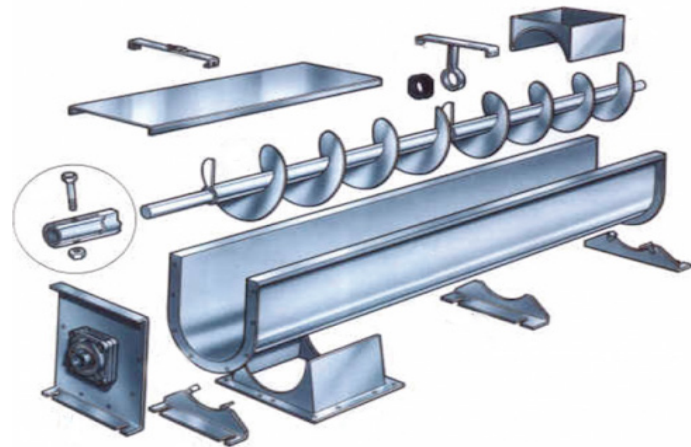

## PARTS

- Conveyor Belts (New & Used)
- Domestic & Import
- Splice Materials (Vulcanized/Mechanical)
- Repair Materials
- Rubber Lining/Lagging
- Belt Cleaners & Blades
- Idlers & Pulleys
- Skirt Board Rubber & Systems
- Custom Rubber Products
- Sleeves, Boots, Gaskets, etc.
- Power Transmission Parts
- Impact Beds & Transfer Points
- Conveyor Covers
- Fasteners & Equipment

## SERVICES

- Installation (All Phases)
- Splicing (Vulcanized/Mechanical)
- Belts up to 120" Wide
- Belt Repairs
- Complete System Fabrication
- Preventative Maintenance
- Contract Maintenance
- Pulley Lagging
- Mechanical Maintenance & Repair
- Training & Troubleshooting
- Consulting & Surveys
- Complete Fabrication Shop



## CORE COMPETENCIES



**Innovative Industrial Solutions**



**Conveyor Belt Installation & Repairs**



**Welding & Fabrication  
(Steel, Stainless, Aluminum)**



**Preventative Mechanical Maintenance**

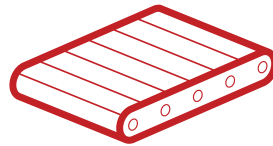

**Hot Vulcanizing, Splicing,  
& Pulley Lagging**

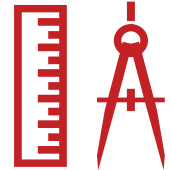

**System Design & Fabrication**



**Conveyor Component Sales & Service**



**Conveyor Safety & Consulting**



**Training & Troubleshooting**



**24/7 Emergency Service**



**Expedient Results**



**Impeccable Customer Service**